

Devon *Royal*LTv

Luxury that goes a long, long way





The ultimate luxury motor caravan. The new Devon Royalty based on the VW LT has a host of impressive fittings, including large fridge, cooker, oven, toilet and shower compartment, hot and cold running water and

thermostatically controlled heating. There is lots of storage space for your clothes, food and equipment. It will take you and your family anywhere in the world in comfort and style.

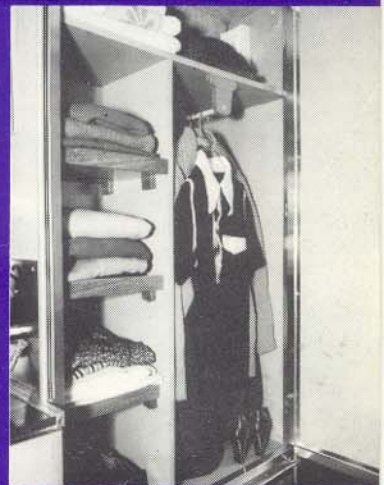

DEVON
RoyalTY
VOLKSWAGEN

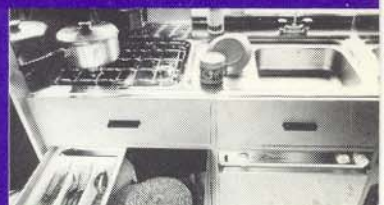

VW Devon

DEVON CONVERSIONS LTD
Alexandria Works, Sidmouth,
Devon EX10 9HA
Telephone (03955) 2345
Telex 42624

Member of the
Renwick Group



Trade Descriptions Act 1968
The policy of Devon Conversions Ltd is one of continuous development, and they reserve the right to change specifications and prices without notice.

Devon Royalty LT

Specifications

Conversion

Lounge/dining room

Two inward facing double seats adjacent to the rear doors, with storage lockers underneath.

An extra cushion is provided to form a pleasant U shaped seating area.

Rich carpet trim covers the interior panels and roof.

The rear door panels are padded and trimmed in the same material as the seat cushions with handy inset pockets.

The rear double doors have louvred windows with fitted flyscreens.

There is an opening roof ventilator above the dining area, with a detachable fly screen.

Carpeting covers the floor and bottom panels of the seat boxes.

The dining table mounts on a single leg between the rear seats.

Deep foam seat cushions are covered in an attractive brown and beige check material.

Bedroom

The large double bed is made by positioning the table between the seats to form the bed base, and arranging the seat cushions transversely across the vehicle.

Extra sleeping room is provided by a double bunk with hard base stored across the rear of the roof of the lounge area. It folds out easily to form a comfortable double bed, with a guard rail/access ladder fitted to the side.

Both the lower and upper double beds have individual lighting and curtains for privacy.

The lower lights have dimmer controls.

There are two fixed rear side windows in the bedroom/lounge area.

Toilet/shower

On the nearside behind the sliding door is a luxurious toilet and shower area. It features a portable flushing toilet, built in vanity unit with mirror, interior light, electric extractor fan, tip-up wash basin, shower curtain, and shower attachment with hot and cold mixer taps. It also has a toilet roll holder, towel hoop, soap dish, toothbrush and mug holder.

Wardrobe

There is a mirror on the inside of the wardrobe door and a useful 240 volt shaving point is fitted inside.

Opposite the shower is a full height hanging wardrobe with a shelf partition on the left-hand side and a full length shelf above.

The shower and wardrobe doors open on opposite sides to give a roomy toilet and changing room in the centre of the vehicle, with fitted carpet.

Kitchen

There's a super L shaped kitchen in the Royalty divided off from the cab.

On the offside is a neat combined cooker and sink unit with flap fronts, incorporating a stainless steel sink with hot and cold mixer taps and draining board, and a two burner cooker with grill.

Underneath the cooker is a large capacity fridge which operates off mains electricity, 12 volt or gas.

Below the sink is a cutlery drawer and a roomy double cupboard with shelves.

A louvred window with removable fly screens is fitted above the kitchen unit.

Handily situated above the cooker is an eye-level oven with an adjacent flap fronted storage cupboard.

On the left-hand side of sliding door is a large storage cabinet. A hinged flap on the side enables the working surface to be extended across to the cooker unit.

A continuous U shaped working surface can be produced by using the sink top cover to span the area between the side of the shower unit and the storage cupboard.

There is a large storage compartment with front opening door above the cab.

Interior room heater

A gas room heater is fitted beneath the wardrobe. It has an underfloor flu, automatic ignition, flame failure device, and is thermostatically controlled.

It blows warm air to outlets in the base of the rear seats.

Water heater

A constant capacity of 6 gal automatic water heater is underfloor mounted. It operates from a gas boiler, is thermostatically controlled and incorporates a flame failure device.

Gas Bottle storage

Gas bottles can be stored in a sealed locker accessible from the outside of the vehicle on the offside.

Water Storage

Underfloor fresh water tank 20 gallons capacity with a separate 10 gallons waste tank.

Spare Wheel is stored in a cradle underneath the rear of the vehicle.

Cabinet work

All upright cabinet surfaces are finished in a textured beige coloured easy-care surface.

All horizontal working surfaces are in identical chocolate coloured material.

Options

Mains electricity including twin battery with split circuit charging system and built in battery charger. Exterior 240 volt connection and 2 spare interior 240 volt sockets.

Full length cab hammock bunk.

Exterior colour stripe.

VW Devon Royalty by day and night

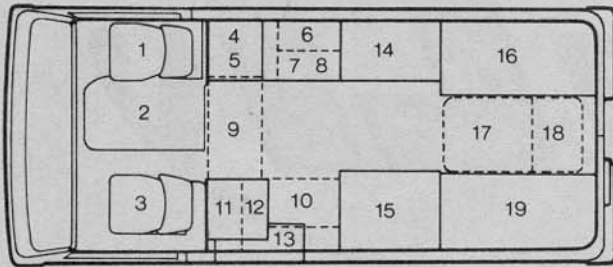

By day

- | | |
|------------------------------|---------------------------------------|
| 1. Driver's seat | 12. Cupboard (water heater beneath) |
| 2. Roof locker over cab area | 13. Step & slide door |
| 3. Passenger's seat | 14. Wardrobe with room heater beneath |
| 4. High level oven | 15. Shower & toilet |
| 5. Cooker | 16. Seats |
| 6. High level cupboard | 17. Swivel table |
| 7. Sink unit | 18. Removable seat |
| 8. Refrigerator (under sink) | 19. Seats |
| 9. Working top (removable) | |
| 10. Working top (removable) | |
| 11. Cupboard (over) | |

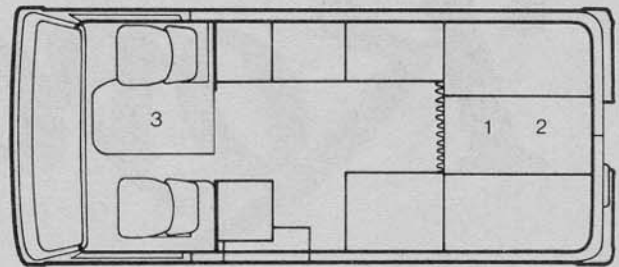

By night

1. Double bed
2. Double bunk bed, with firm base, over bed 1
3. Childs cab hammock bunk (optional extra)

Exterior Dimensions

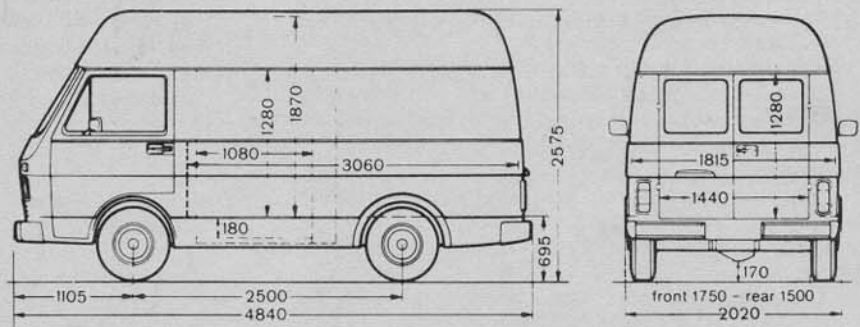

Base Vehicle

LT 28 High Top Panel Van.

Exterior colours: Pastel White
Marino Yellow
Taiga Green
Brilliant Orange

Engine: 2 litre petrol
Option: 2.7 litre Perkins Diesel

Capacities

Fuel Tank — 70 litres
Cooling system — petrol — 10 litres, diesel — 12 litres
Engine oil: Petrol — 4.5 litres, Diesel — 10 litres

Suspension

Front: independent coil spring suspension.
Rear: maintenance free semi elliptic leaf springs.

Electrical System

Voltage: 12 volts, negative earth.

Braking System

Dual circuit servo assisted brakes. Discs on front wheels, self-adjusting drums on rear.

Wheels & Tyres

Wheels: 6J x 14.5 stud
Tyres: 185 R 14C8PR



DEVON CONVERSIONS LTD

Alexandria Works, Sidmouth, Devon EX10 9HA
Telephone (03955) 2345 Telex 42624

Member of the Renwick Group



Trade Descriptions Act 1968.
The policy of Devon Conversions Ltd is one of continuous development, and they reserve the right to change specifications and prices without notice.